

Igo 21

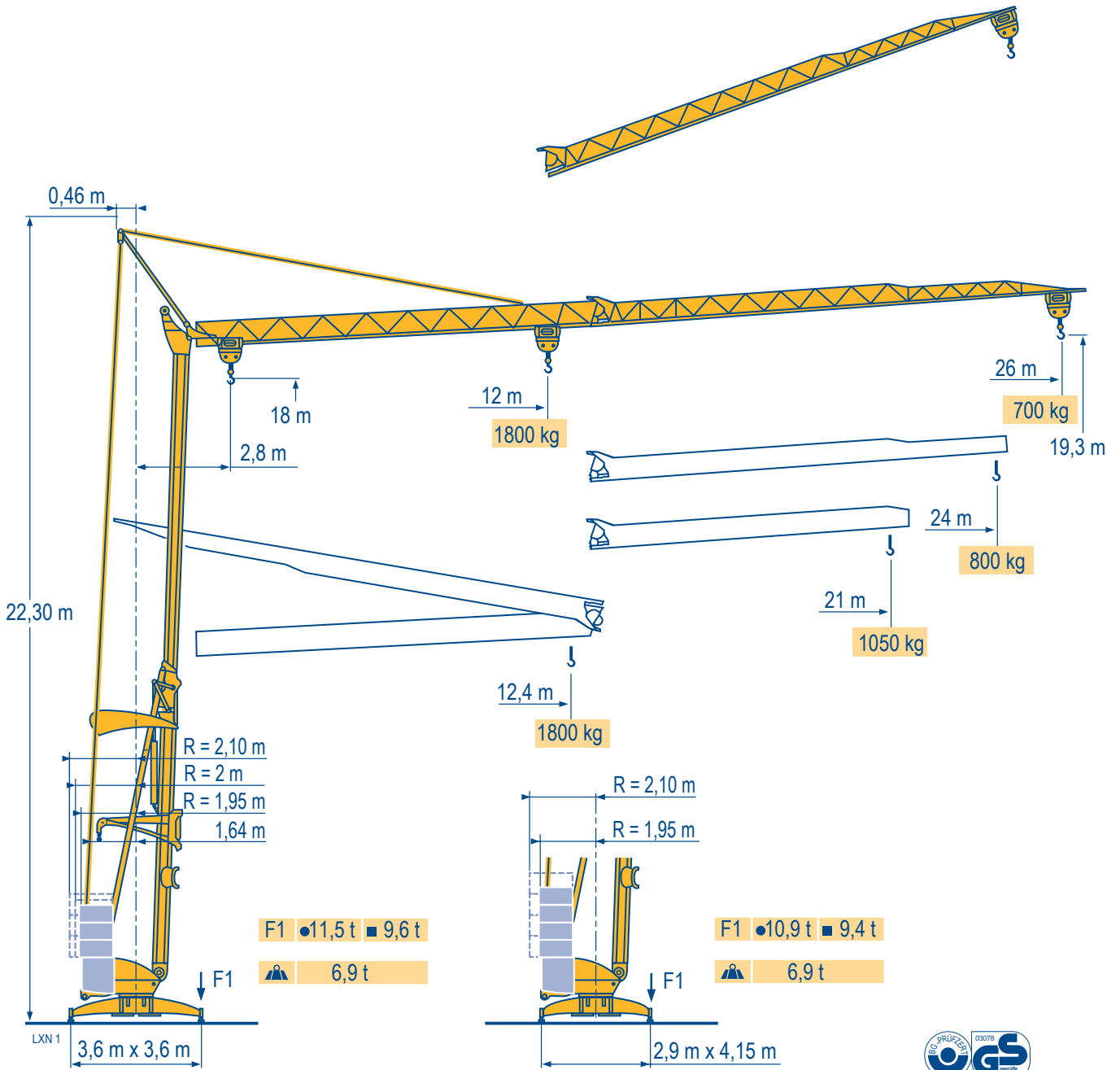

Courbes de charges
Lastkurven
Load diagrams
Curvas de cargas
Curve di carico
Curva de cargas

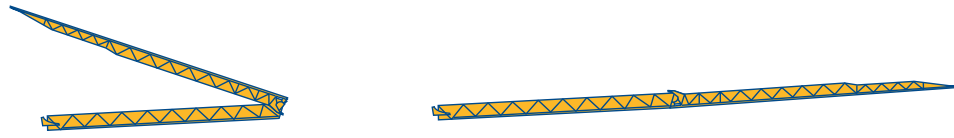

LXN 1

26 m	2,8	▶	12,4 m	12	13	14	15	16	17	18	19	20	21	22	23	24	25	26 m
	1800 kg			1800	1630	1490	1370	1265	1175	1095	1025	965	910	860	815	775	735	700 kg
24 m	2,8	▶	12,4 m	12,3	13	14	15	16	17	18	19	20	21	22	23	24 m		
	1800 kg			1800	1685	1535	1415	1310	1215	1135	1060	1000	940	890	845	800 kg		
21 m	2,8	▶	12,4 m	13,4	14	15	16	17	18	19	20	21 m						
	1800 kg			1800	1710	1570	1455	1350	1265	1185	1115	1050 kg						

Fèche relevée
Ausleger in Steilstellung
Luffing jib
Flecha izada
Braccio impennato
Lança inclinada

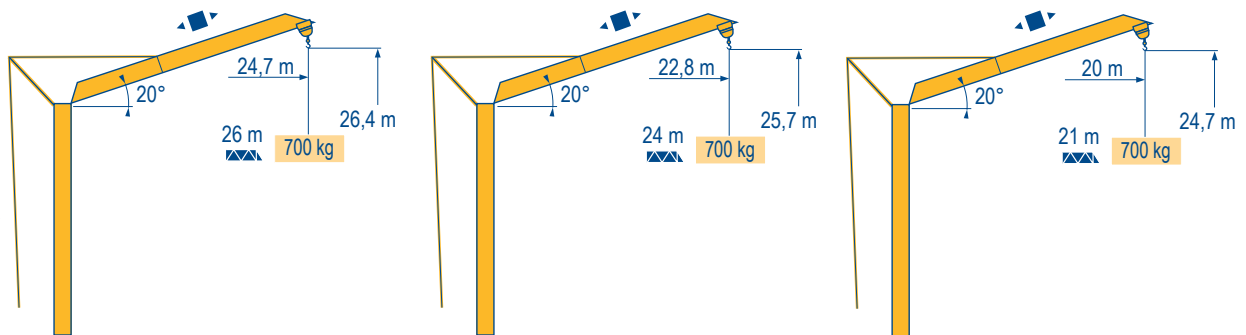

LXN 1

Igo 21

POTAIN



F
Chariot distributeur
Réactions en service
Réactions hors service
A vide sans lest (ni train de transport) avec fèche et hauteur maximum.

D
Verfahrbare Laufkatze
Reaktionskräfte in Betrieb
Reaktionskräfte außer Betrieb
Ohne Last, Ballast (und Transportachse), mit Maximalausleger und Maximalhöhe.

GB
Traversing trolley
Reactions in service
Reactions out of service
Without load, ballast (or transport axes), with maximum jib and maximum height.

E
Carro distribuidor
Reacciones en servicio
Reacciones fuera de servicio
Sin carga, sin lastre, (ni tren de transporte), flecha y altura máxima.

I
Carrellino distributore
Reazioni in servizio
Reazioni fuori servizio
A vuoto, senza zavorra (ne assali di trasporto) con braccio massimo e altezza massima.

P
Carro distribuidor
Reacções em serviço
Reacções fora de serviço
Sem carga (nem trem de transporte)- sem lastro com lança e altura máximas.

Mécanismes
Antriebe
Mechanisms
Mecanismos
Meccanismi
Mecanismos

LXN 3

							ch - PS hp	kW	
	8 LVF 9 Optima	230 V 20 A 1	m/min	↑ 3,5 ↓ 3,5	↑ 7 ↓ 16	↑ 18 ↓ 36	3,3	2,4	
			kg	1800	1800	700			
		230 V 32 A 2	m/min	↑ 3,5 ↓ 3,5	↑ 11 ↓ 16	↑ 25 ↓ 36			
			kg	1800	1800	700	5,2	3,8	
		400 V 3	m/min	↓ 3,5	↓ 16	↓ 36	7,5	5,5	
			kg	1800	1800	700			
	1 DVF 4	-	m/min	14 → 36 (0 → 700 kg) - 14 → 28 (700 → 1800 kg)			1,5	1,1	
	RVF 20	-	tr/min U/min rpm	0 → 1			1,5	1,1	
CEI 38				IEC 38				kVA	
230 V(+6% -10%) 50 Hz				230 V 20 A : 4,6 kVA 230 V 32 A : 7,4 kVA				400 V : 11 kVA	
400 V(+6% -10%) 50 Hz									

8 LVF 9
Optima

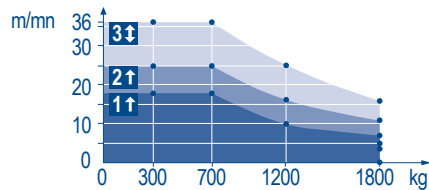

Montage
Montage
Erection
Montaje
Montaggio
Montagem

LXN 1

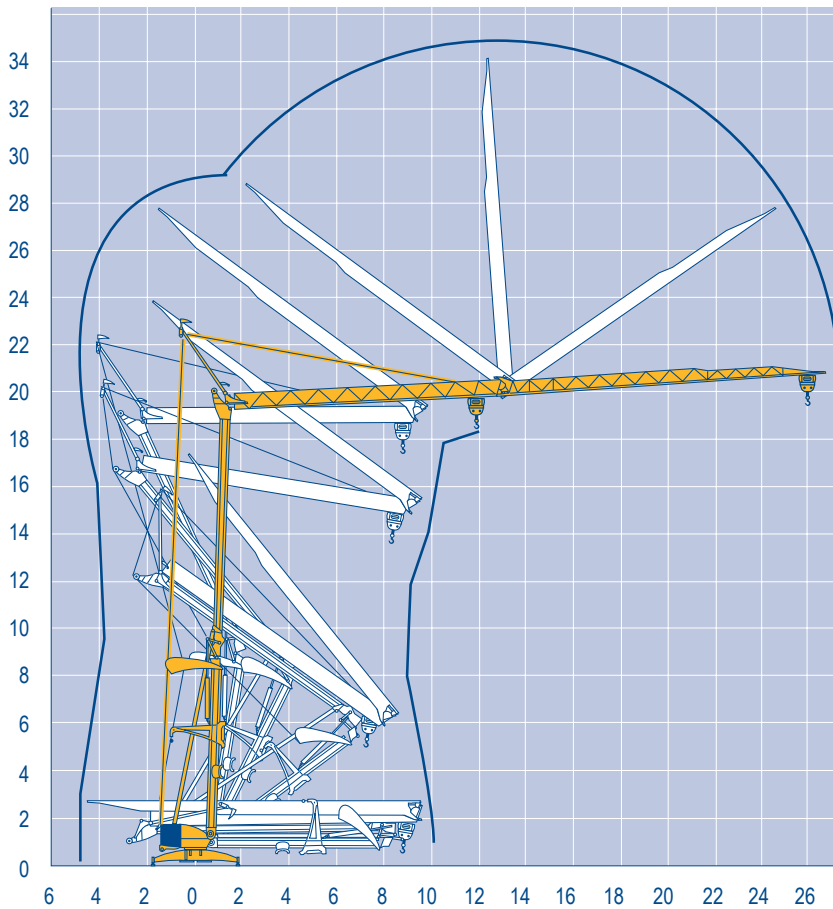

Igo 21

POTAIN

F

Levage
 Distribution
 Orientation
 50 Hz Monophasé

D

Heben
 Katzfahren
 Schwenken
50 Hz Einphasige

GB

Hoisting
 Trolleying
 Slewing
50 Hz Single phase

E

Elevación
 Distribución
 Orientación
50 Hz Monofásica

I

Sollevamento
 Distribuzione
 Rotazione
50 Hz Monofase

P

Elevação
 Distribuição
 Rotação
50 Hz monofásica

Transport
 Transport
 Transport
 Transporte
 Trasporto
 Transporte

LXN 2

- DS51/S70 ○
- DS61/S80 ○
- DS61/S120 ○
- DS61/S125
- DJ80/S120 ○
- DJ80/S125
- DJ100/S120
- DJ105/S125
- DJ126M/S125

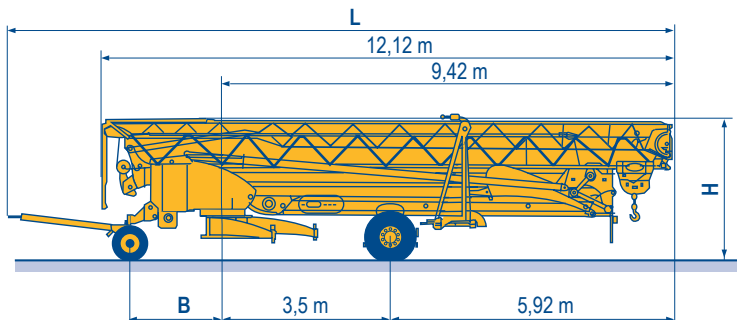

	L (m)	B (m)	H (m)
DS51/S70	14,07	2,33	2,85/3
DS61/S80	14,5	2,43	2,85/3
DS61/S120	14,5	2,43	2,85/3
DS61/S125	14,5	2,43	2,85/3
DJ80/S120	14,5	2,43	3,03
DJ80/S125	14,5	2,43	3,03
DJ100/S120	14,5	2,43	3,36/3,21
DJ105/S125	14,5	2,43	3,36/3,21
DJ126M/S125	14,95	2,43	4

- **F**
Chantier
- D**
Baustelle
- GB**
Site
- E**
Obra
- I**
Cantiere
- P**
Estaleiro

Document commercial non contractuel. Pour toute information technique se référer à la notice correspondante. Unverbindliches Vertriebsdokument. Für technische Informationen, siehe die entsprechenden Anweisungen. This commercial document is not legally binding. For any technical information, please refer to the corresponding instructions. Documento comercial non contractuel. Para cualquier información técnica, ver la noticia correspondiente. Documento commerciale non vincolante, per tutte le informazioni tecniche fare riferimento al catalogo istruzioni. Documento comercial não contratual. Para qualquer informação técnica complementar consultar as respectivas instruções.



**18, rue de Charbonnières - B.R.173
 69132 ECULLY Cedex - France**
 Tél. : +33 (0) 4 72 18 20 20
 Fax. : +33 (0) 4 72 18 20 00
 www.manitowoccrane.com



Americas
 Tel : +1 888 479 7278
 Tel : +1 717 593 2000

Europe - Middle East - Africa
 Tel : +33 (0) 4 72 81 50 00
 Tel : +44 (0) 191 522 2000

Asia - Pacific
 Tel : +65 6264 1188
 Fax : +65 6862 4040

www.manitowoccrane.com

Igo 21

Code S-91985-44_Réf. 2003 48 LXN 5

Copyright.Reproduction interdite © POTAIN 2003

Réalisation Secloc